

AP1: Data Management – Metadata Catalogue

Hinnerk Stüben

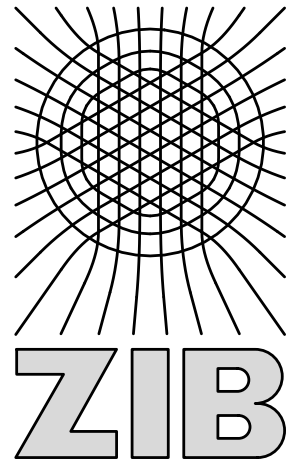

HEPCG Workshop
Wuppertal, 30 November 2006

ILDG — The International Lattice DataGrid

[<http://www.lqcd.org/ildg>]

- *Aim:* Long-term storage and global sharing of data generated on capability computers
→ make more efficient use of expensive data
- *Members:* Australia, France, German, Italy, Japan, UK, US
(Switzerland plans to join)
- *Grid-of-Grids concept:* LatFor DataGrid (LDG) = continental European Grid
[<http://www-zeuthen.desy.de/latfor/ldg>]

-  : implementation of an extensible metadata catalogue

Progress report: MDC

- *MDC*: main requirements:
 - *functionality*: load, store, and query of XML documents which conform to an extensible XML schema defined by ILDG
 - *front-end*: web service conforming to ILDG specification
 - *back-end*: standard relational database
 - *generality*: usefulness for other research communities
- *New*: ILDG has standardised query and download services. The interface is specified by
 - web service description language
 - behavioural specification
 - a test set
- *MDC portal*: <http://www-zeuthen.desy.de/latfor/ldg/mdc>

Progress report: access control (I)

- User can set permissions for a set of files called *ensemble*
 - read permission = right to download data from SE
 - write permission = right to upload/modify metadata in MDC and files on SE
- Concept:
 - define ACL in MDC
 - push ACL to FC (LFC supports POSIX ACL) and possibly to SE
- ACL management controlled by privileges:
 - administrator privilege
 - manager privilege (bound to a project)
 - group privilege (bound to an ensemble)

Progress Report: access control (II)

- Implementation status:
 - concept tested
 - upgrade to LFC done
 - implementation of ACS started

Access control

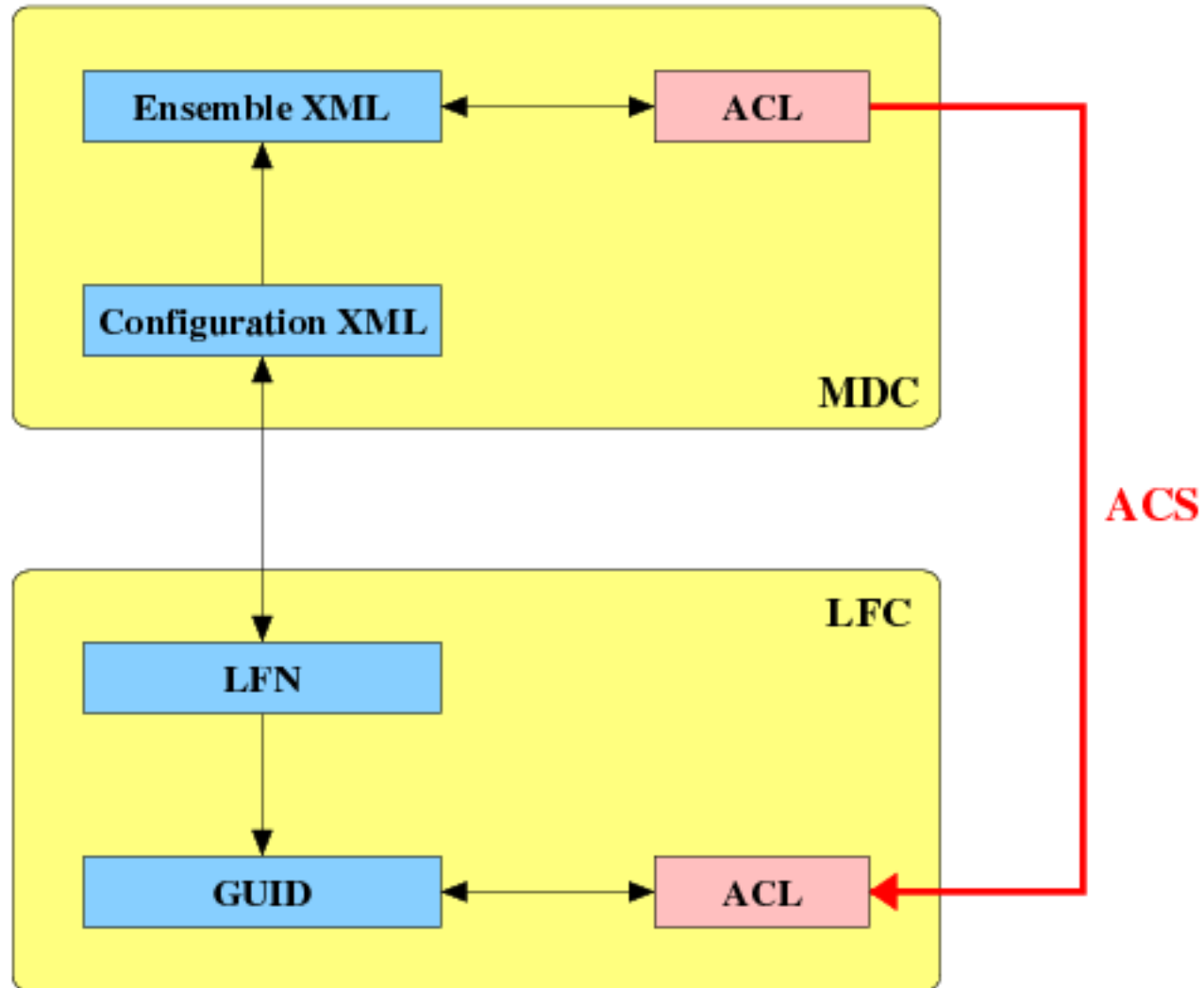

Client software deployment

- Users are typically members of small theory groups
 - No computing infrastructure dedicated for Grid applications
- Requirements:
 - easy to install
 - no root privileges required for installation
 - support for a variety of Linux flavours
- Solution:
 - use Java/perl based software → portable software
 - RPM based installation mechanism
 - easy to manage, no root privileges required

gLite data management client tools

- A GUI is needed for each Linux flavour
- Supported Linux flavours:
 - Debian 3, Fedora Core 3, Red Hat 7, Scientific Linux 3, SLES9, Suse 10
- Components used:
 - Globus/VDT toolkit (2.4)
 - gsoap (2.6) / CGSI-gsoap
 - LFC clients/library (1.5.10)
 - GFAL (1.7.8.6)
 - LCG util (1.3.7.5)
- Packaged using statically linked RPM3
- Problem: access to different systems for compilation
→ consider use of virtualised Linux installations